

EYEPIECE CADDY SET INSTRUCTIONS

PARTS LIST

2" Eyepiece Bracket w. 1 1/4" plastic inserts
1 1/4" Eyepiece Bracket
(4) Thumb Knobs

INTRODUCTION

Thank you for purchasing the Eyepiece Caddy Set. This versatile accessory attaches to the yoke arms of your Tele Vue mount and places five eyepieces conveniently at your fingertips. Also available is a plate to attach the Sky Tour display unit. This plate will mount to either Caddy, using the available clearance holes.

The Caddy Set is precision machined aluminum, and powder-coated for lifetime durability. You may wish to remove them and pack separately when carrying a mount head in luggage.

INSTALLATION

The most current yoke and cradle heads have the attachment holes already drilled into the arms. If your mount arms are not predrilled, you can use a drill press and the enclosed templates to make the holes yourself.

Attach each Caddy bracket by passing the screws through the clearance holes in the yoke arms and tightening the thumb knobs.

The angled edge will match the arms, so that when viewing from the telescope eyepiece position, the (3) 1 1/4" holes will be on the left side, while the (2) 2" holes with removable 1 1/4" plastic plugs will be to your right.

USE

You can place up to (5) 1 1/4" eyepieces in the Caddy Set, or by removing the plastic inserts, use (3) 1 1/4" and (2) 2" eyepieces. To remove the 1 1/4" inserts, push up from the bottom. To reinstall the 1 1/4" inserts, push them in from the top by running your thumbs around the outer lip.

If you have dual barrel eyepieces you can use either 1 1/4" or 2" holes, but the outside lock screw in the 2" eyepiece barrel must be removed.

Of course, your Barlow or Powermate units, or 2" to 1 1/4" adapters can also be placed in the Caddy Set.

Optional Sky Tour Mounting Bracket

The optional Sky Tour Mounting Bracket attaches to either the left or right eyepiece caddy using the two supplied button head screws and Allen wrench. Keep the two halves of the Velcro strip together and stick one side on the back of your Sky Tour computer as shown. Peel the remaining backing off of the Velcro and stick the Sky Tour computer onto the Mounting Bracket. When using shorter scopes like our Tele Vue-76 or Tele Vue-85, make sure you leave enough finger room between the computer and the focuser knob.

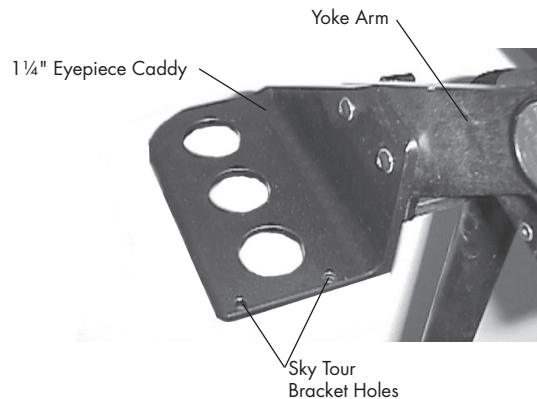
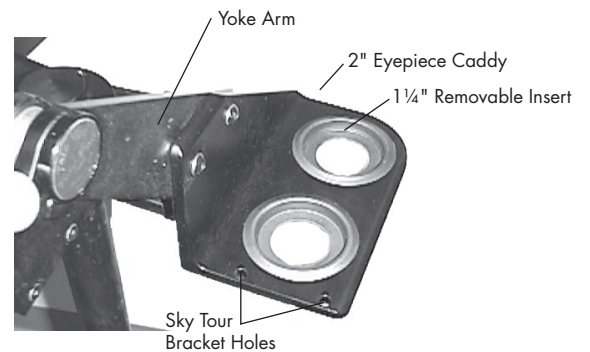
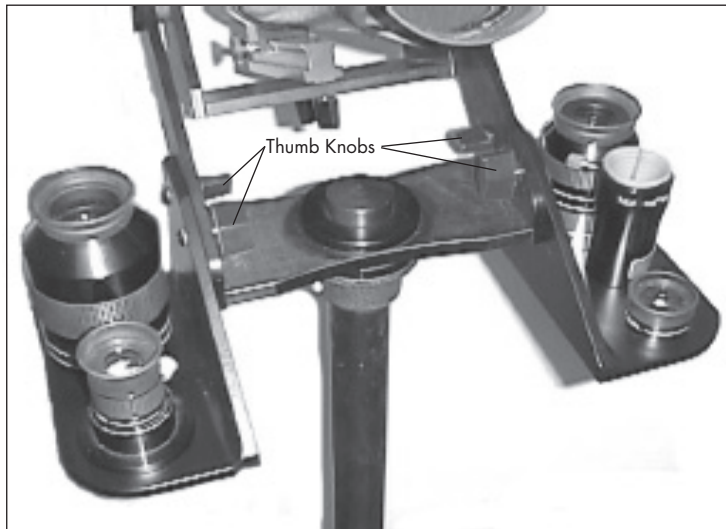

Velcro location on back of Sky Tour.

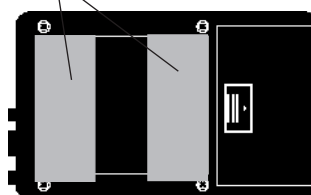

LEFT YOKE ARM TEMPLATE

EYEPIECE CADDY MOUNTING HOLE POSITIONS IN YOKE ARMS OF: PANORAMIC/GIBRALTAR/UP-SWING/TELEPOD HEADS

NOTE: Tele Vue strongly recommends using a drill press, not a hand drill for making these holes.

1) Transfer the measurements from the drawing to your Yoke arm.

Or, cut out the template and tape it to the outside of the Yoke arm, with the bottom and back surfaces aligned with the corresponding surfaces of your yoke arms.

2) Center punch the holes to be drilled.

3) Secure the mount head so it won't move while drilling.

4) Drill the holes with a 17/64 diameter drill.

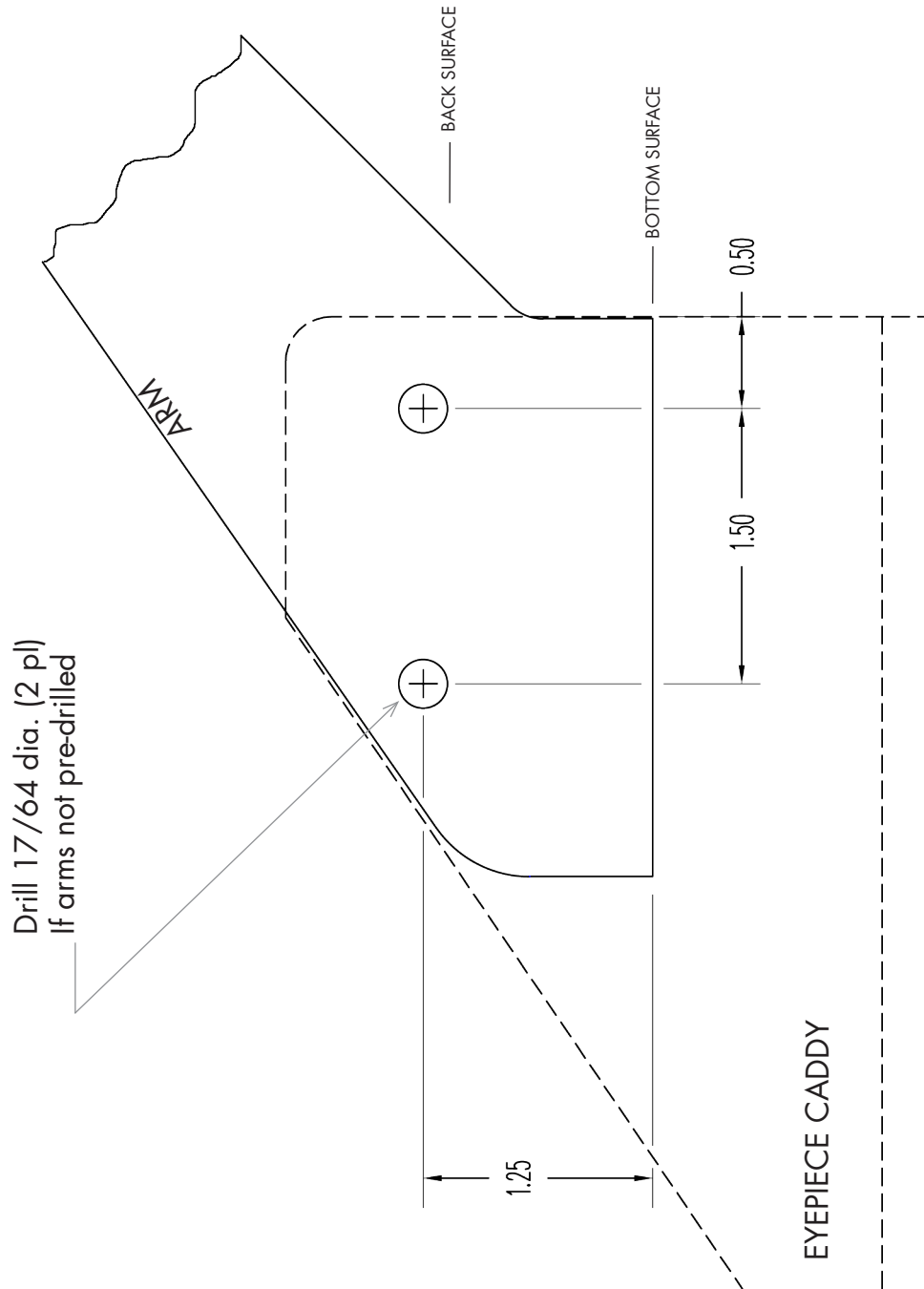

RIGHT YOKE ARM TEMPLATE

EYEPIECE CADDY MOUNTING HOLE POSITIONS IN YOKE ARMS OF: PANORAMIC/GIBRALTAR/UP-SWING/TELEPOD HEADS

NOTE: Tele Vue strongly recommends using a drill press, not a hand drill for making these holes.

1) Transfer the measurements from the drawing to your Yoke arm.

Or, cut out the template and tape it to the outside of the Yoke arm, with the bottom and back surfaces aligned with the corresponding surfaces of your yoke arms.

2) Center punch the holes to be drilled.

3) Secure the mount head so it won't move while drilling.

4) Drill the holes with a 17/64 diameter drill.

